

Register your instrument!
www.eppendorf.com/myeppendorf



MiniSpin®/MiniSpin® plus

Original Operating Instructions

Copyright © 2021 Eppendorf SE, Germany. All rights reserved, including graphics and images. No part of this publication may be reproduced without the prior permission of the copyright owner.

Microtainer® is a registered trademark of Becton Dickinson, USA.

Eppendorf® and the Eppendorf Brand Design are registered trademarks of Eppendorf SE, Germany.

MiniSpin® is a registered trademark of Eppendorf SE, Germany.

Registered trademarks and protected trademarks are not marked in all cases with ® or ™ in this manual.

Table of contents

1	Operating instructions	5
1.1	Using this manual	5
1.2	Danger symbols and danger levels	5
1.2.1	Danger symbols	5
1.2.2	Danger levels	5
1.3	Symbols used	6
1.4	Abbreviations used	6
2	Safety	7
2.1	Intended use	7
2.2	User profile	7
2.3	Application limits	7
2.4	Warnings for intended use	8
2.4.1	Personal injury or damage to device	8
2.4.2	Incorrect handling of the centrifuge	10
2.4.3	Incorrect handling of the rotors	10
2.4.4	Extreme strain on the centrifugation tubes	11
2.5	Safety instructions on the device	12
3	Product description	13
3.1	Product overview	13
3.2	Delivery package	14
3.3	Features	14
3.4	Name plate	15
4	Installation	17
4.1	Selecting the location	17
4.2	Installing the instrument	18
5	Operation	19
5.1	Operating controls	19
5.2	Switching on the centrifuge	20
5.3	Inserting and loading the rotor	20
5.3.1	Inserting the rotor	20
5.3.2	Loading the rotor	20
5.3.3	Positioning the rotor lid	21
5.3.4	Removing the rotor	21
5.4	Centrifuging	21
5.4.1	Closing the centrifuge lid	22
5.4.2	Starting centrifugation	22
5.4.3	Short run centrifugation	22
5.4.4	MiniSpin plus: Switching the display between speed and g-force	22
5.4.5	MiniSpin plus: Centrifuging in continuous operation	23

Table of contents

4 MiniSpin®/MiniSpin® plus English (EN)

6	Maintenance	24
6.1	Service options	24
6.2	Service	24
6.3	Prepare cleaning/disinfection	24
6.4	Cleaning/disinfection	25
6.4.1	Cleaning and disinfecting the device	26
6.4.2	Cleaning and disinfecting the rotor	27
6.5	Decontamination before shipment	27
7	Troubleshooting	28
7.1	General errors	28
7.2	Error messages	28
7.3	Emergency release	30
8	Transport, storage and disposal	31
8.1	Transport	31
8.2	Storage	31
8.3	Disposal	32
9	Technical data	33
9.1	Power supply	33
9.2	Ambient conditions	33
9.3	Weight/dimensions	33
9.4	Noise level	34
9.5	Application parameters	34
9.6	Service life of accessories	35
9.7	Rotors	36
9.7.1	Rotor F-45-12-11	36
9.7.2	Rotor F-55-16-5-PCR	38
10	Ordering Information	39
10.1	Accessories	39
	Certificates	41

1 Operating instructions







1.1 Using this manual

- ▶ Read this operating manual completely before using the device for the first time. Observe the instructions for use of the accessories where applicable.
- ▶ This operating manual is part of the product. Please keep it in a place that is easily accessible.
- ▶ Enclose this operating manual when transferring the device to third parties.
- ▶ The current version of the operating manual for all available languages can be found on our webpage www.eppendorf.com/manuals.

1.2 Danger symbols and danger levels

1.2.1 Danger symbols

The safety instructions in this manual have the following danger symbols and danger levels:

	Biohazard		Explosive substances
	Electric shock		Risk of crushing
	Hazard point		Material damage

1.2.2 Danger levels

DANGER	<i>Will</i> lead to severe injuries or death.
WARNING	<i>May</i> lead to severe injuries or death.
CAUTION	May lead to light to moderate injuries.
NOTICE	May lead to material damage.

1.3 Symbols used

Depiction	Meaning
1. 2.	Actions in the specified order
▶	Actions without a specified order
•	List
<i>Text</i>	Display or software texts
i	Additional information

1.4 Abbreviations used

rcf

Relative centrifugal force : g -force in m/s^2

rpm

Revolutions per minute

UV

Ultraviolet radiation

2 Safety

2.1 Intended use

The MiniSpin/MiniSpin plus is used for the separation of aqueous solutions and suspensions of different densities in approved sample tubes.

The MiniSpin/MiniSpin plus is exclusively intended for use indoors. All country-specific safety requirements for operating electrical equipment in the laboratory must be observed.

2.2 User profile

The device and accessories may only be operated by trained and skilled personnel.

Before using the device, read the operating manual and the instructions for use of the accessories carefully and familiarize yourself with the device's mode of operation.

2.3 Application limits



DANGER! Risk of explosion.

- ▶ Do not use the device in an explosive atmosphere.
 - ▶ Do not operate the device in areas where work with explosive substances is carried out.
 - ▶ Do not use this device to process any explosive or highly reactive substances.
 - ▶ Do not use this device to process any substances which could create an explosive atmosphere.
-

Due to its design and the environmental conditions inside the device, the MiniSpin/MiniSpin plus is not suitable for use in a potentially explosive atmosphere.

The device may only be used in a safe environment, such as in the open environment of a ventilated laboratory or a fume hood. The use of substances that could contribute to a potentially explosive atmosphere is not permitted. The final decision on the risks associated with the use of such substances is the user's responsibility.

2.4 Warnings for intended use

2.4.1 Personal injury or damage to device



WARNING! Electric shock due to damage to the device or mains/power cord.

- ▶ Only switch on the device if the device and mains/power cord are undamaged.
- ▶ Only operate devices that have been properly installed or repaired.
- ▶ In case of danger, disconnect the device from the mains/power supply.



WARNING! Lethal voltages inside the device.

Touching parts under high voltage can cause an electric shock. Electric shocks cause injuries to the heart and respiratory paralysis.

- ▶ Ensure that the housing is closed and undamaged.
 - ▶ Do not remove the housing.
 - ▶ Make sure that no liquids can enter the device.
- Only authorized service staff may open the device.



WARNING! Danger due to incorrect voltage supply.

- ▶ Only connect the device to voltage sources which correspond with the electrical requirements on the name plate.
- ▶ Only use earth/grounded sockets with a protective earth (PE) conductor.
- ▶ Only use mains/power cords that are approved for the technical data specified on the name plate and taking into account national laws and regulations. This also includes testing labels if required by law.



WARNING! Damage to health due to infectious liquids and pathogenic germs.

- ▶ When handling infectious liquids and pathogenic germs, observe the national regulations, the biosafety level of your laboratory, and the manufacturers' Safety Data Sheets and application notes.
- ▶ Wear your personal protective equipment.
- ▶ Consult the "Laboratory Biosafety Manual" (source: World Health Organization, Laboratory Biosafety Manual, as amended) for comprehensive regulations on the handling of germs or biological material of risk group II or higher.



WARNING! Risk of injury when opening or closing the centrifuge lid.

There is a risk of crushing your fingers when opening or closing the centrifuge lid.

- ▶ Do not reach between the device and centrifuge lid when opening or closing the centrifuge lid.
- ▶ Do not reach into the locking mechanism of the centrifuge lid.
- ▶ Open the centrifuge lid fully to ensure that the centrifuge lid cannot slam shut.



WARNING! Risk of injury from rotating rotor.

If the emergency release of the lid is operated, the rotor may continue to rotate for several minutes.

- ▶ Wait for the rotor to stop before activating the emergency release.
- ▶ To check, look through the monitoring glass in the centrifuge lid.



WARNING! Risk of injury from chemically or mechanically damaged accessories.

Even minor scratches and cracks can lead to severe internal material damage.

- ▶ Protect all accessory parts from mechanical damage.
- ▶ Inspect the accessories for damage before each use. Replace any damaged accessories.
- ▶ Do not use any accessories which have exceeded their maximum service life.



CAUTION! Risk of burns to the fingers.

The bottom of the centrifuge becomes very hot during the run.

- ▶ Check the temperature at the bottom of the centrifuge before lifting the centrifuge.
- ▶ Only hold the centrifuge at the sides.



CAUTION! Poor safety due to incorrect accessories and spare parts.

The use of accessories and spare parts other than those recommended by Eppendorf may impair the safety, functioning and precision of the device. Eppendorf cannot be held liable or accept any liability for damage resulting from the use of accessories and spare parts other than those recommended or from improper use.

- ▶ Only use accessories and original spare parts recommended by Eppendorf.

**NOTICE! Damage to the device due to spilled liquids.**

1. Switch off the device.
2. Disconnect the device from the mains/power supply.
3. Carefully clean the device and the accessories in accordance with the cleaning and disinfection instructions in the operating manual.
4. If a different cleaning and disinfecting method is to be used, contact Eppendorf SE to ensure that the intended method will not damage the device.

**NOTICE! Damage to electronic components due to condensation.**

Condensate may form in the device after it has been moved from a cool environment to a warmer environment.

- ▶ After installing the device, wait for at least 3 h. Only then connect the device to the mains/power line.

2.4.2 Incorrect handling of the centrifuge

**NOTICE! Damage from knocking against or moving the device during operation.**

If the rotor hits the rotor chamber wall, it will cause considerable damage to the device and rotor.

- ▶ Do not move or knock against the device during operation.

2.4.3 Incorrect handling of the rotors

**WARNING! Risk of injury from improperly attached rotors and rotor lids.**

- ▶ Only centrifuge with the rotor and rotor lid firmly tightened.
- ▶ If any unusual noises occur when the centrifuge starts, the rotor or the rotor lid may not be attached properly. Stop the centrifugation immediately.

**CAUTION! Risk of injury due to asymmetric loading of a rotor.**

- ▶ Load rotors symmetrically with identical tubes.
- ▶ Only load adapters with suitable tubes.
- ▶ Always use the same type of tubes (weight, material/density and volume).
- ▶ Use a balance to check that the load is symmetrical by balancing the adapters and tubes that are used.



CAUTION! Risk of injury from overloaded rotor.

The centrifuge is designed for the centrifugation of material with a maximum density of 1.2 g/mL at maximum speed and filling volume and/or load.

- ▶ Do not exceed the maximum load of the rotor.



NOTICE! Damage to rotors from aggressive chemicals.

Rotors are high-quality assemblies designed to withstand extreme stresses. This stability can be impaired by aggressive chemicals.

- ▶ Avoid using aggressive chemicals such as strong and weak alkalis, strong acids, solutions with mercury ions, copper ions and other heavy metal ions, halogenated hydrocarbons, concentrated saline solutions and phenol.
- ▶ If it is contaminated by aggressive chemicals, clean the rotor and especially the rotor bores immediately using a neutral cleaning agent.
- ▶ Due to the manufacturing process, color variations may occur on PTFE coated rotors. These color variations do not affect the service life or resistance to chemicals.

2.4.4 Extreme strain on the centrifugation tubes



CAUTION! Risk of injury from overloaded tubes.

- ▶ Note the loading limits specified by the tube manufacturer.
- ▶ Only use tubes which are approved by the manufacturer for the required *g*-forces (rcf).



NOTICE! Danger from damaged tubes.

Damaged tubes must not be used, as this could cause further damage to the device and the accessories and loss of the samples.

- ▶ Visually check all tubes for damage before use.



NOTICE! Danger due to deformed or brittle material. Autoclaving at excessively high temperatures can lead to plastic tubes, adapters and rotor lids becoming brittle and deformed.

This could result in damage to the device and the accessories and sample loss.

- ▶ Observe the temperatures specified by the manufacturer when autoclaving tubes.
- ▶ Do not use any deformed or brittle tubes.



NOTICE! Danger from open tube lids.

Open tube lids may break off during centrifugation and damage both the rotor and the centrifuge.

- ▶ Carefully seal all tube lids before centrifuging.



NOTICE! Damage to plastic tubes due to organic solvents.

The density of plastic tubes is reduced when organic solvents (e.g. phenol, chloroform) are used, i.e. the tubes may become damaged.

- ▶ Note the manufacturer’s information on the chemical resistance of the tubes.





NOTICE! Micro test tubes heat up.

In non-refrigerated centrifuges, the temperature in the rotor chamber, rotor and sample may increase to above 40 °C, depending on the run time, *g*-force (rcf)/ speed and ambient temperature.

- ▶ Please note that this will reduce the centrifugation stability of the micro test tubes.
- ▶ Please note the temperature resistance of the samples.

2.5 Safety instructions on the device

Symbol	Meaning	Location
	NOTICE ▶ Observe the safety instructions in the operating manual.	Rear of the device
	▶ Observe operating manual.	

3 Product description
3.1 Product overview

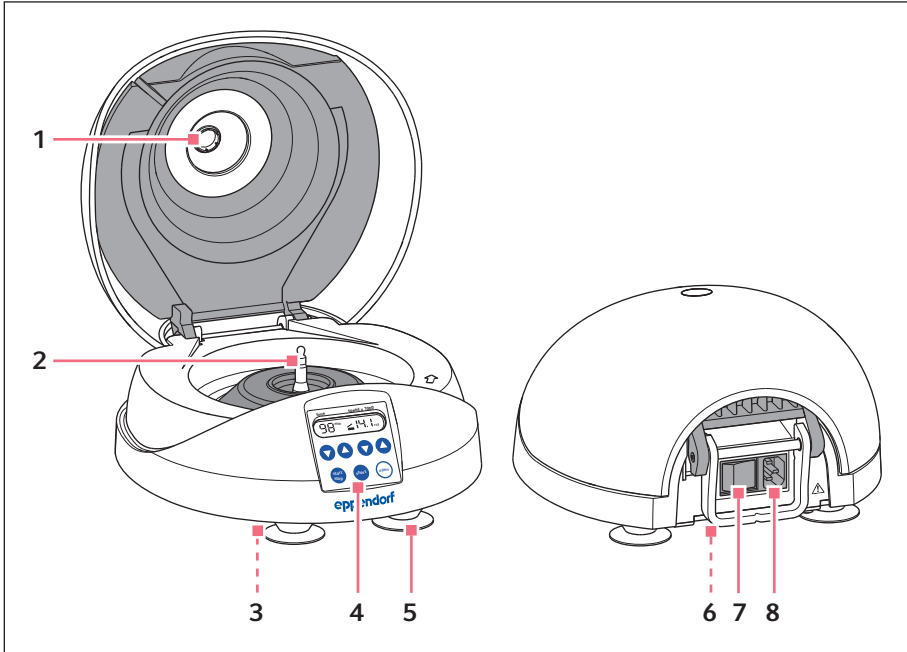

- | | |
|--|---------------------------------|
| 1 Monitoring glass | 5 Suction foot |
| 2 Motor shaft | 6 Name plate (bottom of device) |
| 3 Emergency release (bottom of device) | 7 Mains/power switch |
| 4 Control panel | 8 Mains/power cord socket |

Product description

MiniSpin®/MiniSpin® plus
English (EN)

3.2 Delivery package

1 or	CentrifugeMiniSpin CentrifugeMiniSpin plus
1	Rotor F-45-12-11 incl. rotor lid
1	Rotor nut
1	Mains/power cord
1	Operating manual



- ▶ Check whether the delivery is complete.
- ▶ Check all parts for transport damage.
- ▶ To safely transport and store the device, retain the transport box and packing material.

3.3 Features

The high-power and user-friendly microcentrifuges MiniSpin and the MiniSpin plus are so small that each workstation can be equipped with a "personal" centrifuge. For the MiniSpin and the MiniSpin plus, 2 rotors are available:

Fixed-angle rotor F-45-12-11

Capacity: 12 tubes

- Micro test tubes 0.2 mL to 2.0 mL
- Microtainers

Fixed-angle rotor F-55-16-5-PCR

Capacity: 16 PCR tubes

- 0.2 mL PCR tubes
- PCR strips

3.4 Name plate

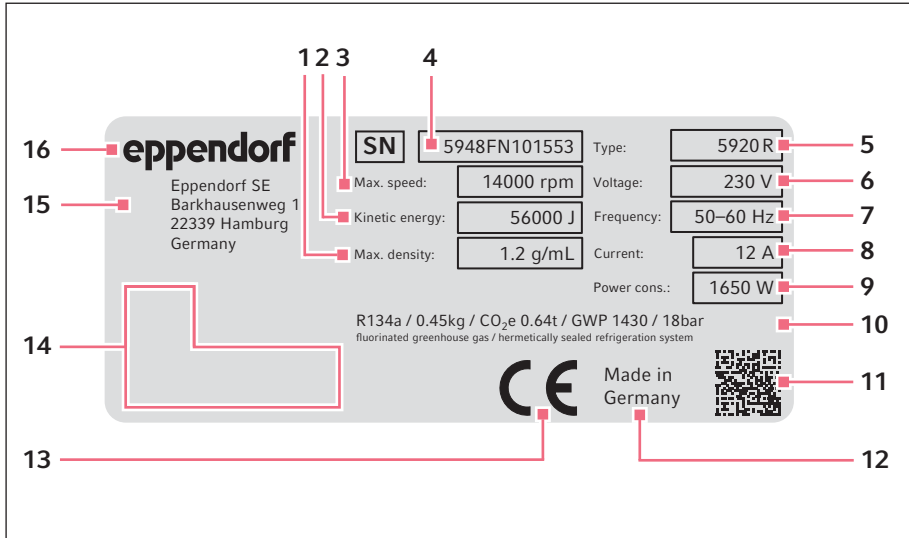







Fig. 3-1: Device identification of Eppendorf SE (example)

- | | |
|---|--|
| <ul style="list-style-type: none"> 1 Maximum density of the material for centrifuging 2 Maximum kinetic energy 3 Maximum speed 4 Serial number 5 Product name 6 Rated voltage 7 Rated frequency 8 Maximum rated current | <ul style="list-style-type: none"> 9 Maximum rated power 10 Information on the refrigerant (refrigerated centrifuges only) 11 Data matrix code for serial number 12 Designation of origin 13 CE marking 14 Certification marks and symbols (device-specific) 15 Manufacturer's address 16 Manufacturer |
|---|--|

Product description

MiniSpin®/MiniSpin® plus
English (EN)

Tab. 3-1: Certification marks and symbols (device-specific)

Symbol/certification mark	Meaning
	Serial number
	Symbol for waste electrical and electronic equipment (WEEE) according to EU Directive 2012/19/EU, European Community
	UL listing certification mark: Declaration of conformity, USA
	Certification mark for electromagnetic compatibility of the <i>Federal Communications Commission</i> , USA
	Certification mark China – Use of certain hazardous substances in electrical and electronic products (<i>Requirements for Concentration Limits for Certain Hazardous Substances in Electronic Information Products SJ/T 11363-2006</i>), People's Republic of China

4 Installation

4.1 Selecting the location



WARNING! Danger due to incorrect voltage supply.

- ▶ Only connect the device to voltage sources which correspond with the electrical requirements on the name plate.
 - ▶ Only use earth/grounded sockets with a protective earth (PE) conductor.
 - ▶ Only use mains/power cords that are approved for the technical data specified on the name plate and taking into account national laws and regulations. This also includes testing labels if required by law.
-



NOTICE! If a fault occurs, any objects in the immediate proximity of the device will be damaged.

- ▶ In accordance with the recommendations of EN 61010-2-020, leave a safety clearance of **30 cm** around the device during operation.
- ▶ Please remove all materials and objects from this area.



NOTICE! Damage due to overheating.

- ▶ Do not install the device near heat sources (e.g., heating, drying cabinets).
- ▶ Do not expose the device to direct sunlight.
- ▶ Ensure unobstructed air circulation. Maintain a clearance of at least 30 cm around all ventilation gaps.



NOTICE! Radio interference.

For devices with Class A noise emission in accordance with DIN EN 61326-1:2013-07 and DIN EN 55011:2018-05, the following applies: This device has been developed and tested in accordance with CISPR 11 Class A. The device may cause radio interference in domestic environments and is not intended for use in residential areas. The device cannot ensure adequate protection of radio reception in residential areas and domestic environments.

- ▶ If necessary, take appropriate measure to eliminate the interferences.
-



Mains/power connection for centrifuges: Operation of the centrifuge is only permitted in building installations that comply with the applicable national regulations and standards. In particular, it must be ensured that there are no impermissible loads on the supply lines and assemblies that are located upstream of the internal protection of the device. This can be ensured by using additional circuit breakers or other suitable fuse elements in the building installation.



The mains/power switch and the disconnecting device of the mains/power line must be easily accessible during operation (e.g., a residual current circuit breaker).

Select the location for the device according to the following criteria:

- Mains/power connection in accordance with the name plate
 - Minimum distance to other devices and walls: 30 cm
 - A resonance-free table with a horizontal, even work surface
 - The location has good ventilation.
 - The location is protected against direct sunlight.
- ▶ Do not use this device near strong electromagnetic sources (e.g., unshielded high frequency sources) as they could impair the proper operation of the device.

4.2 Installing the instrument

Prerequisites

- The centrifuge is on a suitable lab bench with a smooth surface.
- Suction feet are fixed to the surface.



WARNING! Danger due to incorrect voltage supply.

- ▶ Only connect the device to voltage sources which correspond with the electrical requirements on the name plate.
- ▶ Only use earth/grounded sockets with a protective earth (PE) conductor.
- ▶ Only use mains/power cords that are approved for the technical data specified on the name plate and taking into account national laws and regulations. This also includes testing labels if required by law.



NOTICE! Damage to electronic components due to condensation.

Condensate may form in the device after it has been moved from a cool environment to a warmer environment.

- ▶ After installing the device, wait for at least 3 h. Only then connect the device to the mains/power line.

1. Let the centrifuge warm up to ambient temperature.
2. Connect the centrifuge to the mains/power line and switch it on using the mains/power switch.
 - The display is active.
 - The centrifuge lid opens.

5.2 Switching on the centrifuge

- ▶ Switch the centrifuge on using the mains/power switch at the rear of the device.
 - The lid opens.
 - The display shows the parameters of the last run.

5.3 Inserting and loading the rotor



WARNING! Risk of injury from chemically or mechanically damaged accessories.

Even minor scratches and cracks can lead to severe internal material damage.

- ▶ Protect all accessory parts from mechanical damage.
 - ▶ Inspect the accessories for damage before each use. Replace any damaged accessories.
 - ▶ Do not use any accessories which have exceeded their maximum service life.
-

5.3.1 Inserting the rotor

1. Fit the rotor on the motor shaft.
2. Fit the rotor nut on the motor shaft.
3. Rotate the rotor nut **clockwise** and tighten it.

5.3.2 Loading the rotor



CAUTION! Risk of injury due to asymmetric loading of a rotor.

- ▶ Load rotors symmetrically with identical tubes.
 - ▶ Only load adapters with suitable tubes.
 - ▶ Always use the same type of tubes (weight, material/density and volume).
 - ▶ Use a balance to check that the load is symmetrical by balancing the adapters and tubes that are used.
-

1. Check maximum load (adapter, vessel, and contents) for each rotor bore.
2. Load rotors and adapters only with the tubes intended for them.
3. To ensure symmetrical loading, insert sets of two tubes in opposite bores. Tubes located opposite each other must be of the same type and contain the same filling quantity.

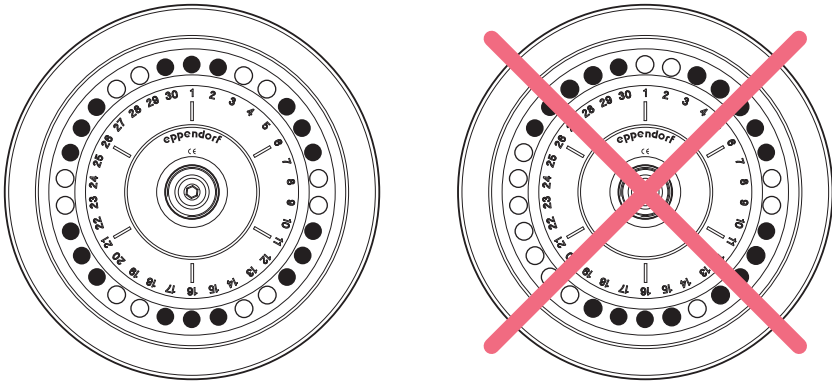

5.3.3 Positioning the rotor lid

- ▶ Position the rotor lid on the rotor. The rotor lid audibly engages.

5.3.4 Removing the rotor

1. Pull up the knob of the rotor lid and remove the rotor lid.
2. Turn the rotor nut **counterclockwise** and remove it.
3. Remove the rotor.

5.4 Centrifuging



WARNING! Risk of injury from improperly attached rotors and rotor lids.

- ▶ Only centrifuge with the rotor and rotor lid firmly tightened.
- ▶ If any unusual noises occur when the centrifuge starts, the rotor or the rotor lid may not be attached properly. Stop the centrifuging immediately.

5.4.1 Closing the centrifuge lid

**WARNING! Risk of injury when opening or closing the centrifuge lid.**

There is a risk of crushing your fingers when opening or closing the centrifuge lid.

- ▶ Do not reach between the device and centrifuge lid when opening or closing the centrifuge lid.
 - ▶ Do not reach into the locking mechanism of the centrifuge lid.
 - ▶ Open the centrifuge lid fully to ensure that the centrifuge lid cannot slam shut.
-

1. Check the correct attachment of the rotor and rotor lid.
2. Press the centrifuge lid down until it is gripped by the lid latch.

5.4.2 Starting centrifugation

Setting the centrifugation parameters

1. Set the centrifugation time with the **time** arrow keys.
2. Set the centrifugation speed with the **speed** arrow keys.

Starting the centrifugation run

3. To start the centrifugation run, press the **start/stop** key.

Display during centrifugation

- The bar in the center of the display flashes alternately at the top and bottom.
- Remaining run time in minutes. The last minute is counted down in seconds.
- Current speed (rpm) or *g*-force (rcf) (MiniSpin plus).



During the run, you can change the centrifugation time and the centrifugation speed. The new parameters are adopted immediately.

5.4.3 Short run centrifugation

- **MiniSpin:** Short run centrifugation at maximum speed (13400 rpm)
 - **MiniSpin plus:** The speed of the short run centrifugation can be set.
1. Start short run centrifugation: Keep the **short** key pressed.
 - The bar in the center of the display flashes alternately at the top and bottom.
 - The cycle time is counted up.
 2. Stop short run centrifugation: Release the **short** key.
 - During the braking process, the elapsed running time flashes on the display.
 - The centrifuge lid opens automatically.

5.4.3.1 MiniSpin plus: Setting the speed of the short spin centrifugation

Prerequisites

The centrifuge lid is open.

- ▶ Keep the **short** key pressed until the display changes.
 - *14t*: Short run centrifugation at maximum speed (14500 rpm)
 - *1 – 14t*: Short run centrifugation at set speed (rpm) or *g*-force (rcf)
- ▶ For *1 – 14t*, set the speed (rpm) or *g*-force (rcf) with the **speed** arrow key.

5.4.4 MiniSpin plus: Switching the display between speed and *g*-force

- ▶ Press both **speed** ▼ and ▲ arrow keys simultaneously.
The display changes from *rpm* (speed) to *rcf* (*g*-force) and vice versa.



It is possible to switch the display between speed and *g*-force during a centrifugation run.

For the MiniSpin, you can use the following formula to calculate the *g*-force for the displayed speed according to DIN 58 970:

$$rcf = 1.118 \cdot 10^{-5} \cdot n^2 \cdot r_{\max}$$

n: speed in min⁻¹

*r*_{max}: maximum centrifugation radius in cm

Example: The maximum centrifugation radius of the rotor F-45-12-11 is 6 cm. At a speed of 10200 rpm, a maximum *g*-force of 7000 × *g* is reached.

5.4.5 MiniSpin plus: Centrifuging in continuous operation

Setting continuous run

1. In order to centrifuge without any time limits, use the **time** arrow keys to select the setting *oo* (▼ below 15 s or ▲ above 99 min).
2. Set the speed (rpm) or *g*-force (rcf) with the **speed** arrow keys.
3. To start the centrifugation run, press the **start/stop** key.
 - The bar in the center of the display flashes alternately at the top and bottom.
 - The cycle time is counted up.
 - Current speed (rpm) or *g*-force (rcf).
4. Press the **start/stop** key to end the centrifugation.
 - During the braking process, the elapsed running time flashes on the display.

6 Maintenance

6.1 Service options

Eppendorf recommends having your device checked and maintained by trained specialist personnel at regular intervals.

Eppendorf offers you tailor-made service solutions for the preventive maintenance, qualification and calibration of your device. For information, offers and contact options, please visit www.eppendorf.com/epservices.

6.2 Service



WARNING! Risk of fire or electrical shock

- ▶ Have the centrifuge's electrical safety, especially the continuity of the protective connections, checked every 12 months by trained and skilled personnel.
-

We recommend to have the centrifuge and the associated rotors checked by Technical Service during a service at least every 12 months. Please note the country-specific regulations.

6.3 Prepare cleaning/disinfection

- ▶ Clean all accessible surfaces of the device and the accessories at least weekly and when contaminated.
- ▶ Clean the rotor regularly. This way the rotor is protected and the durability is prolonged.
- ▶ Furthermore, observe the notes on decontamination (see *Decontamination before shipment on p. 27*) when the device is sent to the authorized Technical Service for repairs.

The procedure described in the following chapter applies to the cleaning as well as to the disinfection or decontamination. The table below describes the steps required on top of this:

Cleaning	Disinfection/decontamination
<ol style="list-style-type: none"> 1. Use a mild cleaning fluid to clean the accessible surfaces of the device and the accessories. 2. Carry out the cleaning as described in the following chapter. 	<ol style="list-style-type: none"> 1. Choose the disinfection method which corresponds to the legal regulations and guidelines in place for your range of application. For example, use alcohol (ethanol, isopropanol) or alcohol-based disinfectants. 2. Carry out the disinfection or decontamination as described in the following chapter. 3. Then clean the device and the accessories.



If you have any further questions regarding cleaning and disinfection or decontamination or regarding the cleaning agents to be used, contact the Application Support of Eppendorf SE. The contact details are provided on the back of this manual.

6.4 Cleaning/disinfection



DANGER! Electric shock due to the ingress of liquid.

- ▶ Switch off the device and disconnect it from the mains/power line before commencing any cleaning or disinfection procedures.
- ▶ Do not allow any liquids to enter the inside of the housing.
- ▶ Do not spray clean/spray disinfect the housing.
- ▶ Do not reconnect the device to the mains/power line unless both the inside and outside of the device are completely dry.



NOTICE! Damage due to aggressive chemicals.

- ▶ Do not use any aggressive chemicals on the device or its accessories, such as strong and weak bases, strong acids, acetone, formaldehyde, halogenated hydrocarbons or phenol.
- ▶ If the device has been contaminated by aggressive chemicals, clean it immediately using a mild cleaning agent.

**NOTICE! Corrosion due to aggressive cleaning agents and disinfectants.**

- ▶ Do not use any corrosive cleaning agents, aggressive solvents or abrasive polishes.
- ▶ Do not incubate the accessories in aggressive cleaning agents or disinfectants for longer periods.

**NOTICE! Damage from UV and other high-energy radiation.**

- ▶ Do not use UV, beta or gamma rays, or any other high-energy forms of radiation for disinfection.
- ▶ Avoid storage in areas with high UV radiation.

**NOTICE! Danger due to deformed or brittle tubes. Autoclaving at excessively high temperatures can lead to plastic vessels becoming brittle and deformed.**

This could result in damage to the device and the accessories and sample loss.

- ▶ Observe the temperatures specified by the manufacturer when autoclaving tubes.
- ▶ Do not use any deformed or brittle tubes.

**Autoclaving**

All rotors, rotor lids and adapters can be autoclaved (121 °C, 20 min).

6.4.1 Cleaning and disinfecting the device

If you have any additional questions regarding disinfection, decontamination, cleaning and the cleaning agents to be used, please contact the Application Support of Eppendorf SE. The contact details are provided on the back of this manual.

1. Open the lid. Switch off the device using the mains/power switch. Disconnect the mains/power plug from the voltage supply.
2. Loosen the rotor nut by turning the rotor nut counterclockwise.
3. Remove the rotor.
4. Clean and disinfect all accessible surfaces on the device including the mains/power cord using a damp cloth and the recommended cleaning agents.
5. Clean the motor shaft using a soft, dry, lint-free cloth. Do not grease the motor shaft.
6. Check the motor shaft for any damage.
7. Inspect the device for any corrosion and damage.
8. Leave the centrifuge lid open when the device is not in use.
9. Only reconnect the device to the mains/power supply if it is fully dry on the inside and on the outside.

6.4.2 Cleaning and disinfecting the rotor

1. Inspect the rotor and accessories for any damage and corrosion. Do not use any damaged rotors or accessories.
2. Clean and disinfect the rotors and accessories using the recommended cleaning agents.
3. Use a bottle brush to clean and disinfect the rotor bores.
4. Rinse the rotors and accessories thoroughly with distilled water. Rinse the rotor bores of fixed-angle rotors particularly thoroughly.



Do not put the rotor into the dishwasher and do not immerse the rotor in liquid, as liquid may enter through the openings.

5. Place the rotors and accessories on a towel to dry. Place fixed-angle rotors with the rotor bores facing down so the bores can also dry.
6. Clean the rotor cone with a soft, dry, lint-free cloth. Do not lubricate the rotor cone.
7. Inspect the rotor cone for damage.
8. Place the dry rotor onto the motor shaft.
9. Tighten the rotor nut by turning it clockwise.
10. Leave the rotor lid open when the rotor is not being used.

6.5 Decontamination before shipment

If you are shipping the device to the authorized Technical Service for repairs or to your authorized dealer for disposal please note the following:



WARNING! Risk to health from contaminated device.

1. Observe the information contained in the decontamination certificate. It is available as a PDF document on our webpage (<https://www.eppendorf.com/decontamination>).
 2. Decontaminate all parts to be shipped.
 3. Include the fully completed decontamination certificate in the shipment.
-

7 Troubleshooting

If you cannot remedy an error with the recommended measures, please contact your local Eppendorf partner. The contact address can be found on the Internet at www.eppendorf.com.

7.1 General errors

Problem	Cause	Solution
No display.	No mains connection.	<ul style="list-style-type: none"> ▶ Check the mains connection. ▶ Check the mains fuse of the laboratory.
	Power failure.	<ul style="list-style-type: none"> ▶ Check the mains connection. ▶ Check the mains fuse of the laboratory.
The centrifuge lid cannot be opened.	Rotor is still running.	▶ Wait for the rotor to stop.
	Error message with locking time. Locking period still running.	▶ Wait for the locking time to elapse.
The centrifuge cannot be started.	Centrifuge lid is not closed.	▶ Close the centrifuge lid.
Centrifuge shakes when it starts up.	Rotor loaded unsymmetrically.	<ol style="list-style-type: none"> 1. Stop the centrifuge and load the rotor symmetrically. 2. Re-start the centrifuge.

7.2 Error messages

Key lock after error message

- If an error message occurs, the keys remain locked as long as the rotor is moving.
- For some errors, the remaining blocking time and the error message are alternately shown on the display. The blocking time also remains active if the centrifuge is disconnected from the mains/power line.

If an error message appears, proceed as follows:

- ▶ Remedy the fault as described in the "Remedy" column.
- ▶ Wait for the blocking time to elapse or the rotor to stop.
- ▶ To clear the error message from the display, press the **open** key.

Problem	Cause	Solution
<i>Er 3.1</i> <i>Er 3.2</i> <i>Er 3.3</i> <i>Er 3.4</i> <i>Er 3.5</i>	Error in speed measuring system.	<ul style="list-style-type: none"> ▶ Tighten rotor. ▶ Wait for the blocking time to elapse. ▶ Press the open key.
<i>Er 6.1</i> <i>Er 6.2</i> <i>Er 6.3</i> <i>Er 6.4</i>	<ul style="list-style-type: none"> • Error in the drive electronics. • The drive is overheated. 	<ul style="list-style-type: none"> ▶ Repeat the run. <p>If the error message appears again:</p> <ol style="list-style-type: none"> 1. Switch off centrifuge and wait for 20 s. 2. Switch on the centrifuge. <p>If the error message appears again:</p> <ul style="list-style-type: none"> ▶ Let the drive cool down for at least 15 min.
<i>Er 10.0</i> <i>Er 10.1</i> <i>Er 10.2</i>	Electronics fault.	<ol style="list-style-type: none"> 1. Switch off centrifuge and wait for 20 s. 2. Switch on the centrifuge.
<i>Er 15.1</i> <i>Er 15.2</i> <i>Er 16.2</i> <i>Er 16.3</i> <i>Er 16.4</i>	Electronics fault.	<ol style="list-style-type: none"> 1. Switch off centrifuge and wait for 20 s. 2. Switch on the centrifuge.
<i>Int</i>	Mains/power failure during a run.	<ul style="list-style-type: none"> ▶ Check the power supply. ▶ Press the open key.
<i>Lid</i>	Centrifuge lid will not lock.	<ul style="list-style-type: none"> ▶ Press the open key. ▶ Try again to close centrifuge lid.
	Centrifuge lid cannot be released.	<ul style="list-style-type: none"> ▶ Switch off centrifuge and wait for 20 s. ▶ Switch on the centrifuge. ▶ Press the open key. <p>If the error occurs again:</p> <ol style="list-style-type: none"> 1. Switch off centrifuge. 2. Activate the emergency lid release.
	Emergency release was actuated during a run.	<ul style="list-style-type: none"> ▶ Wait for the rotor to stop. ▶ Press the open key.

7.3 Emergency release

If the centrifuge lid cannot be opened during a power failure, you can activate the emergency release manually.



WARNING! Risk of injury from rotating rotor.

If the emergency release of the lid is operated, the rotor may continue to rotate for several minutes.

- ▶ Wait for the rotor to stop before activating the emergency release.
- ▶ To check, look through the monitoring glass in the centrifuge lid.



CAUTION! Risk of burns to the fingers.

The bottom of the centrifuge becomes very hot during the run.

- ▶ Check the temperature at the bottom of the centrifuge before lifting the centrifuge.
- ▶ Only hold the centrifuge at the sides.

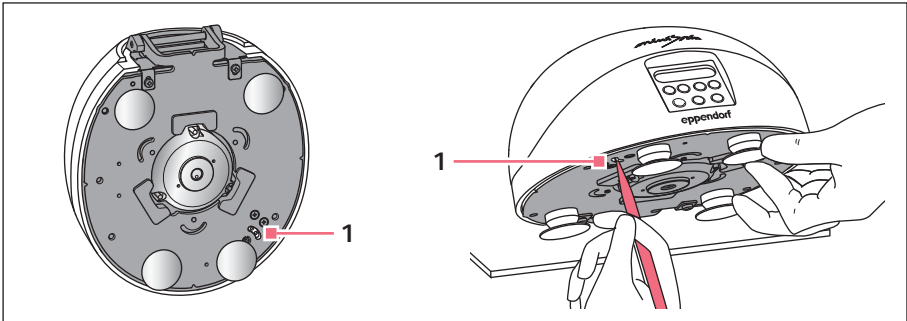

1. Pull out the mains/power plug and wait for the rotor to stop.
2. Lift up the centrifuge. Use a ball pen to move the disk behind the opening of the bottom panel clockwise until the centrifuge lid opens.

8 Transport, storage and disposal

8.1 Transport

- ▶ Remove the rotor from the centrifuge before transport.
- ▶ Use the original packaging and the transport securing devices for transport.

	Air temperature	Relative humidity	Atmospheric pressure
General transport	-25 °C – 60 °C	10 % – 75 %	30 kPa – 106 kPa
Air freight	-20 °C – 55 °C	10 % – 75 %	30 kPa – 106 kPa

8.2 Storage

	Air temperature	Relative humidity	Atmospheric pressure
In transport packing	-25 °C – 55 °C	10 % – 75 %	70 kPa – 106 kPa
Without transport packing	-5 °C – 45 °C	10 % – 75 %	70 kPa – 106 kPa

8.3 Disposal

Observe the relevant legal regulations when disposing of the product.

Information on the disposal of electrical and electronic devices in the European Community:

Within the European Community, the disposal of electrical devices is regulated by national regulations based on EU Directive 2012/19/EU pertaining to waste electrical and electronic equipment (WEEE).

According to these regulations, any devices supplied after August 13, 2005, in the business-to-business sphere, to which this product is assigned, may no longer be disposed of in municipal or domestic waste. They are marked with the following symbol to indicate this:

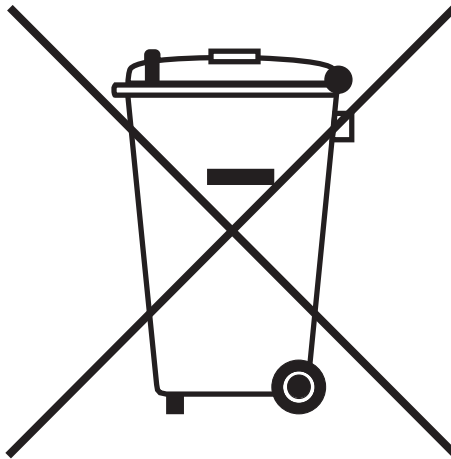

As the disposal regulations may differ from one country to another within the EU, please contact your supplier for more information.

9 Technical data
9.1 Power supply

	MiniSpin	MiniSpin plus
Mains/power connection	230 V, 50 Hz – 60 Hz 120 V, 50 Hz – 60 Hz 100 V, 50 Hz – 60 Hz	230 V, 50 Hz – 60 Hz 120 V, 50 Hz – 60 Hz 100 V, 50 Hz – 60 Hz
Power consumption	70 W	85 W
Current consumption	0.45 A (230 V) 0.9 A (120 V) 1.0 A (100 V)	0.6 A (230 V) 1.2 A (120 V) 1.3 A (100 V)
Overvoltage category	II	
EMC: Noise emission (radio interference)	230 V – EN 61326-1 / EN 55011 – Class B 120 V – CFR 47 FCC Part 15 – Class B 100 V – EN 61326-1 / EN 55011 – Class B	
EMC: Noise immunity	EN 61326 – 1 – basic electromagnetic environment	
Pollution degree	2	

9.2 Ambient conditions

Environment	For indoor use only. The surroundings must not be moist.
Ambient temperature	10 °C – 40 °C
Relative humidity	10 % – 75 %, non-condensing.
Atmospheric pressure	79,5 kPa – 106 kPa

9.3 Weight/dimensions

	MiniSpin	MiniSpin plus
Dimensions	Width: 225 mm Depth: 230 mm Height: 130 mm	
Weight without rotor	3.7 kg	
Rotor weights:		
F-45-12-11	450 g	
F-55-16-5-PCR	210 g	

Technical data

MiniSpin®/MiniSpin® plus
English (EN)

9.4 Noise level

The noise level was measured according to (DIN EN ISO 3745) frontally in a sound measuring chamber (anechoic room) of accuracy class 1 at a distance of 1 m from the device and at lab bench height.

	MiniSpin	MiniSpin plus
Noise level	< 49 dB(A)	< 52 dB(A)

9.5 Application parameters

	MiniSpin	MiniSpin plus
Run time	15 s – 30 min	<ul style="list-style-type: none"> • 15 s – 99 min • unlimited (oo)
	<ul style="list-style-type: none"> • 15 s – 1 min: can be set in increments of 15 s • from 1 min: can be set in increments of 1 min 	
Rotational speed	800 rpm – 13400 rpm	800 rpm – 14500 rpm
	can be set in increments of 100 rpm Tolerance at maximum rotational speed: 3 %	
Relative centrifugal force	$100 \times g$ – $12\,100 \times g$	$100 \times g$ – $14\,100 \times g$ can be set in increments of $100 \times g$
Maximum load	12 × 2,0 mL	
Maximum kinetic energy	870J	1020J
Permitted density of the material for centrifuging (at maximum g -force (rcf) or rotational speed (rpm) and maximum load)	1.2 g/mL	
Acceleration time at maximum rotational speed	≤18 s	
Deceleration time at maximum rotational speed	≤14 s	
Compulsory testing in Germany	No	

9.6 Service life of accessories



CAUTION! Danger due to material fatigue.

If the service life is exceeded, it cannot be guaranteed that the material of the rotors and the accessories will withstand the stresses during centrifugation.

- ▶ Do not use any accessories which have exceeded their maximum service life.

Eppendorf states the maximum service life of rotors and accessories both in years and in the maximum number of cycles. The decisive factor for the service life is which case occurs first, usually this is the number of years in operation.

Each centrifugation run during which the rotor is accelerated and braked is counted as a cycle, independent of the speed and the duration of the centrifugation run.

All other rotors and rotor lids can be used during the entire service life of the centrifuge if the following conditions are met:

- proper use
- recommended maintenance
- undamaged condition

Accessories	Maximum service life after first initial setup
Rotor lid of polycarbonate (PC), polypropylene (PP) or polyetherimide (PEI)	3 years
Aerosol-tight rotor lids with exchangeable seal (e.g., QuickLock rotor lids)	3 years (replace seals every 50 autoclaving cycles)
Non-aerosol-tight rotor lids	3 years
Adapter	1 year

The date of manufacture is stamped on the rotors and buckets in the format *03/15* or *03/2015* (= March 2015). On the inside of the plastic rotor lids and aerosol-tight caps, the date of manufacture is stamped in the form of a clock .

Technical data

MiniSpin®/MiniSpin® plus
English (EN)

9.7 Rotors

Eppendorf centrifuges may only be operated with rotors that are intended for use with the corresponding centrifuge.





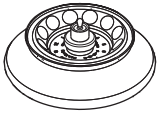

► Only use rotors that are intended for use with the corresponding centrifuge.

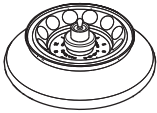

9.7.1 Rotor F-45-12-11

Fixed-angle rotor for 12 tubes

**Rotor F-45-12-11**

	Maximum <i>g</i> -force:	MiniSpin MiniSpin plus	12100 × <i>g</i> 14100 × <i>g</i>
	Maximum speed:	MiniSpin MiniSpin plus	13400 rpm 14500 rpm
	Maximum load (tubes and contents):		12 × 4 <i>g</i>

Tube	Tube Capacity Tubes per adapter/ rotor	Adapter Order no. (international)	Bottom shape Tube diameter	Maximum <i>g</i> -force: Maximum speed: Radius	
	PCR tube 0.2 mL 1/30	 5425 715.005	conical Ø 11 mm	MiniSpin MiniSpin plus MiniSpin MiniSpin plus	7830 × <i>g</i> 9170 × <i>g</i> 13400 rpm 14500 rpm 3.9 cm
	Tube 0.4 mL 1/30	 5425 717.008	conical Ø 6 mm	MiniSpin MiniSpin plus MiniSpin MiniSpin plus	12100 × <i>g</i> 14100 × <i>g</i> 13400 rpm 14500 rpm 6.0 cm
	Tube 0.5 mL 1/30	 5425 716.001	conical Ø 6 mm	MiniSpin MiniSpin plus MiniSpin MiniSpin plus	9840 × <i>g</i> 11520 × <i>g</i> 13400 rpm 14500 rpm 4.9 cm

Tube	Tube Capacity Tubes per adapter/ rotor	Adapter Order no. (international)	Bottom shape Tube diameter	Maximum <i>g</i> -force: Maximum speed: Radius	
	Microtainers 0.6 mL 1/30	 5425 716.001	open Ø 8 mm	MiniSpin MiniSpin plus MiniSpin MiniSpin plus	12 100 × <i>g</i> 14 100 × <i>g</i> 13 400 rpm 14 500 rpm 6.0 cm
	Tube 1.5 ml/2.0 mL -/30		Ø 11 mm	MiniSpin MiniSpin plus MiniSpin MiniSpin plus	12 100 × <i>g</i> 14 100 × <i>g</i> 13 400 rpm 14 500 rpm 6.0 cm

Technical data

MiniSpin®/MiniSpin® plus
English (EN)

9.7.2 Rotor F-55-16-5-PCR

Fixed-angle rotor for 16 PCR tubes



**Rotor
F-55-16-5-PCR**

Maximum <i>g</i> -force:	MiniSpin MiniSpin plus	9840 × <i>g</i> 11520 × <i>g</i>
Maximum speed:	MiniSpin MiniSpin plus	13400 rpm 14500 rpm
Maximum load (tubes and contents):		16 × 0.43 g (2 × 3.5 g)

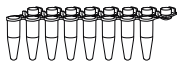
Tubes	Tube Capacity Tubes per adapter/rotor	Bottom shape Tube diameter	Maximum <i>g</i> -force: Maximum speed: Centrifugation radius
	0.2 mL -/16	conical Ø 6 mm	MiniSpin MiniSpin plus MiniSpin MiniSpin plus 9840 × <i>g</i> 11520 × <i>g</i> 13400 rpm 14500 rpm 4.9 cm
	PCR strips 0.2 mL -/2 × 8	conical Ø 6 mm	MiniSpin MiniSpin plus MiniSpin MiniSpin plus 9840 × <i>g</i> 11520 × <i>g</i> 13400 rpm 14500 rpm 4.9 cm

10 Ordering Information
10.1 Accessories

Order no. (International)	Order no. (North America)	Description
5452 725.000 5452 720.008	022668501 022668498	Rotor F-45-12-11 angle 45°, 12 places, max. tube diameter 11 mm, incl. rotor lid and rotor nut MiniSpin MiniSpin/MiniSpin plus
5452 702.000	022668510	Rotor lid for rotor F-45-12-11 stainless steel, with rotor nut
5452 727.007	022665821	Rotor F-55-16-5-PCR angle 55°, 16 places, max. tube diameter 5 mm, incl. rotor lid (aluminum) MiniSpin/MiniSpin plus
5452 730.008	022665847	Rotor lid for rotor F-55-16-5-PCR aluminum, with rotor nut
5452 729.000	022668455	Rotor nut for MiniSpin, MiniSpin plus
5425 716.001	022636227	Adapter used in FA-45-48-11, FA-45-30-11, F-45-30-11, F-45-48-11, F-45-70-11, FA-45-24-11, FA-45-24-11-Special, FA-45-24-11-HS and FA-45-24-11-Kit for 1 sample tube (0.5 mL, max. Ø 6 mm) or 1 Microtainer (0.6 mL, max. Ø 8 mm), set of 6
5425 717.008	022636243	Adapter used in FA-45-48-11, F-45-12-11, FA-45-18-11, FA-45-30-11, F-45-30-11, F-45-24-11, F-45-70-11, FA-45-24-11-HS, FA-45-24-11-Kit and S-24-11-AT for 1 micro test tube (0.4 mL, max. Ø 6 mm), set of 6
5425 715.005	022636260	Adapter used in FA-45-48-11, F-45-48-11, FA-45-30-11, F-45-30-11, F-45-24-11, F-45-70-11, FA-45-24-11, FA-45-24-11-Special, FA-45-24-11-HS and FA-45-24-11-Kit for 1 PCR tube (0.2 mL, max. Ø 6 mm), set of 6

40 **Ordering Information**
MiniSpin®/MiniSpin® plus
English (EN)

Order no. (International)	Order no. (North America)	Description
0013 563.934	–	Mains/power cord 230 V/50 Hz, Europe
0013 594.490	–	230 V/50 Hz, GB/HK
0013 613.952	–	230 V/50 Hz, CN
0013 592.454	–	230 V/50 Hz, AUS
0013 613.973	–	230 V/50 Hz, ARG
0013 563.942	022377183	120 V USA

Declaration of Conformity

The product named below fulfills the requirements of directives and standards listed. In the case of unauthorized modifications to the product or an unintended use this declaration becomes invalid. This declaration of conformity is issued under the sole responsibility of the manufacturer.

Product name:

Centrifuge MiniSpin®, Centrifuge MiniSpin® plus
including components

Product type:

Centrifuge

Relevant directives / standards:

2006/42/EC: DIN EN ISO 12100 + Cor.1

2014/35/EU: DIN EN 61010-1, DIN EN 61010-2-020

2014/30/EU: DIN EN 61326-1, DIN EN 55011

2011/65/EU: DIN EN IEC 63000
(incl. (EU) 2015/863)

Further applied standards: IEC 61010-1 + Cor. + A1 + A1/Cor.1, IEC 61010-2-020
UL 61010-1, UL 61010-2-020
CAN/CSA C22.2 No. 61010-1-12, CAN/CSA C22.2 No. 61010-2-020
IEC 61326-1, CISPR 11 + A1, 47 CFR FCC part 15
YY/T 0657, GB 4793.1, GB 4793.7, GB 18268.1, YY/T 0466.1, SJ/T 11364,
GB/T 26572

Person authorized to compile

the technical file acc. to 2006/42/EC: Dr. Marlene Jentzsch
Senior Vice President
Division Separation & Instrumentation
Eppendorf SE

Hamburg, November 09, 2021



Dr. Wilhelm Plüster
Management Board



Dr. Marlene Jentzsch
Senior Vice President
Division Separation & Instrumentation

Your local distributor: www.eppendorf.com/contact
Eppendorf SE · Barkhausenweg 1 · 22339 Hamburg · Germany
eppendorf@eppendorf.com

Eppendorf®, the Eppendorf Brand Design and MiniSpin® are registered trademarks of Eppendorf SE, Germany.
All rights reserved, incl. graphics and pictures. Copyright ©2021 by Eppendorf SE.

ISO
9001
Certified

ISO 13485
Certified

ISO 14001
Certified

CERTIFICATE OF COMPLIANCE

Certificate Number 2017-03-22, 2019-04-16 (Am1)-E215059
Report Reference E215059-D1000-1/A1/C0-UL
Issue Date 2017-03-22, 2019-04-16 (Am1)

Issued to: EPPENDORF A G
Applicant Company: BARKHAUSENWEG 1
22339 HAMBURG GERMANY

Listed Company: Same as applicant

This is to certify that representative samples of Centrifuge
5452 (MiniSpin), 5453 (MiniSpin plus)

Have been investigated by UL in accordance with the Standard(s) indicated on this Certificate.

Standard(s) for Safety: UL 61010-1, 3rd Edition, May 11, 2012, Revised July 15 2015, CAN/CSA-C22.2 No. 61010-1-12, 3rd Edition, Revision dated July 2015

Additional Standards: UL 61010-2-020, Third Edition (2016)

Additional Information: See the UL Online Certifications Directory at www.ul.com/database for additional information.

Only those products bearing the UL Certification Mark should be considered as being covered by UL's Certification and Follow-Up Service.

Look for the UL Certification Mark on the product.

This is to certify that representative samples of the product as specified on this certificate were tested according to the current UL requirements.



Bruce Mahrenholz, Assistant Chief Engineer, Global Inspection and Field Services, UL LLC
Joseph Hoxey, General Manager, Director of Sales – Canada, UNDERWRITERS LABORATORIES OF CANADA INC.

Any information and documentation involving UL Mark services are provided on behalf of UL LLC (UL) or any authorized licensee of UL. For questions, please contact a local UL Customer Service Representative www.ul.com/contactus





Evaluate Your Manual

Give us your feedback.
www.eppendorf.com/manualfeedback

Your local distributor: www.eppendorf.com/contact
Eppendorf SE · Barkhausenweg 1 · 22339 Hamburg · Germany
eppendorf@eppendorf.com · www.eppendorf.com